

THE TRAIL RIDER



The Official Newsletter of the Trail Riders of the West, a Video Club Dedicated to the Saturday Matinee Westerns

VOLUME V, No. V

SERIES No. 45 -- JUNE 1993

We Like Seeing This

The weekly Trail Rider meetings are becoming more and more enjoyable as the membership in the club grows. Over the last several issues of the *TRAIL RIDER*, we have introduced you to a couple of new Trail Riders, and in this issue we are introducing you to two more! Isn't it just great seeing more and more people share in and enjoy the Trail Rider *experience*? You Bet! And there are more new members coming in who we will introduce you to in our next issue. Terr-riff-ic! Just terr-riff-ic!

Howdy Grizz!

Trail Rider "Golden Grizz" is Bob Schenk outside of Wednesday nights and character actor and stuntman "Bad Bob" on weekends when he is part of the Groat Gang, a well-known and popular Western show group. Bob, for all intents and purposes, is a native Californian, having moved here with his parents in the early 1940s, and has been a resident of Simi Valley since 1949. Retired from the electronics industry, Bob spends his time enjoying his early firearms collection hobby. Besides being "Bad Bob" with the Groat Gang and "Grizz" with the Trail Riders, he is a member of "The Muzzle Loader Gun Club." Wonder what nick name they call him there? If you would like to write to Grizz and his wife Marjorie, please address your letter to: Mr. and Mrs. Robert C. Schenk, 4343 Avenida Simi, Simi Valley, California 93063.

Howdy Kiowa Slim!

Will Lacey became "Kiowa Slim" last month as he joined all the Trail Riders in remembering yesterday's Saturday matinee Westerns and serials. Will's memories come from the "Ellis Theatre" in Perrytown, Texas, where he enjoyed many Saturdays. He recently remembered those Saturdays in a poem that we have reprinted in this issue of the *TRAIL RIDER*. Sure speaks for all our memories! Yep, Will is a Trail Rider, and we welcome this talented writer to the club with the handle of Kiowa Slim. If you would like to write Kiowa Slim, and welcome him and Miss Wilma Irvine to the Trail Riders, his mailing address is: Mr. Will Lacey, 2829 Royal Avenue, Simi Valley, California 93065.

Happy Birthday



Get the old fire extinguisher ready again Roper, 'cause on June 2nd, the Trail Riders will be lighting up candles again as we celebrate the June birthdays of Trail Rider Montana and William "Hopalong Cassidy" Boyd. Gonna be a gala meeting and all of us are hoping that Durango remembers the words this time as we raise our voices to sing "Happy Birthday."

WHAT'S INSIDE?

- Ya Shoulda' Been There! - 2
- Heard at the Meetings - 3
- Dale Evans Receives Angel Award - 3
- We Had Visitors! - 3
- Trail Riders Hit the Trails - 3
- Tumbleweed Express - 4
- New Skew - 4
- Tip of the White Hat - 4
- The Horseshoe Tournament - 5
- Tip of the White Hat - 5
- Your 1993 Trail Rider Officers - 5
- Red Ryder Daisy B.B. Shoot-out - 6
- Trail Drive to H'wood Collector's Show - 7
- Trail Riders' June Schedule - 7
- Budd Buster Says: - 7
- Movies Watched in April - 7
- Saturday Matinee - 8
- Comin' Up (and a Side Note) - 9
- Matinee Q&A - 9
- Rounding-Up with Buck - 10

Hoppy's Bike

Thanks to Wrangler Bob Owens for the advertisement on the Hopalong Cassidy bike. Sure is purty. Something I once had and can no longer afford. Only 12 are currently available and each costs a whopping

See "Hoppy's Bike" on Page 5

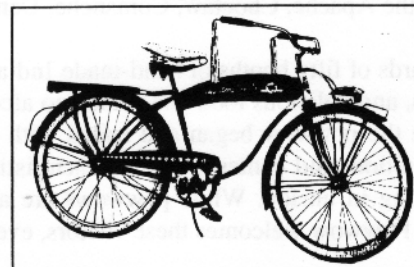

Ya Shoulda' Been There!

By Dick "Colorado" Oakes



CORRIGANVILLE FUND RAISER

Here's a little more about the goin's on at the Corriganville Preservation Committee's April 25th fund raiser for the rebuilding of Ray "Crash" Corrigan's Silvertown and its movie ranch environs.

Simi Valley's Mayor Stratton proclaimed that Sunday *CpC Day*. The proclamation was awarded to CpC president Steve Gillum by City Councilman Bill Davis. Also getting in the act was County Supervisor Vicki Howard, who bid highest for a donated framed John Wayne picture to which they had Eral Williamson affix his own autograph! Speaking of look-alikes, Roy Rogers imitator Bill Nolt was there doing his cowboy yodelling. And if you looked closely, you'd swear that was Glenn Ford that just passed you by! Performers abounded at the CpC function, with 72-year-old Ricky "The Spider" Silva doing his famous double gun-twirling routine (Mr. Silva did pistol "hand inserts" in many films), and Steve Gillum himself giving his American West oratory. There were several appearances by the Corriganville Players, and one of its members, Dave Freeman donated one of his personally hand-made and autographed Indian flutes for auction (snapped up with the highest bid by yours truly, Dick "Colorado" Oakes!).

Trail Rider Jack "Buck" and Miss Joyce Harding were there listening to the music and watching the Colorado-Miss Carol dance team do their cowboy two-step. Music was provided by Trail Rider Rick "Texas Red" Tucker's outfit and The Overland Express, and the shindig was MC'd by Dennis Morgan Strange. Singers included recording artist Diana Blair, actor Jon Locke, and the always hilarious jumpin' jack guitar plunker and baladeer Foggy Mountain. Among the many celebrities partaking of the festivities and tasty barbecued tri-tip dinner could be found Wrangler Dave Pitts, Monte Laird, "Sharkey" Jim Brown, Bill Raymond, Bill Williams, Jerry Best, Debbie Gillum, and "Mama" Brett (wife of "Cherokee Jim" Brett).

But probably the highlight of the day was the question-and-answer session by Lee Aakers of the *Rin Tin Tin* series (of which 196 episodes were and 164 shown). Besides telling about his parts in *Destry* with Audy Murphy, and *High Noon*, with Gary Cooper, Mr. Aakers recounted many stories about being on set with Rand Brooks, Tommy Farrell, and yes, Rin Tin Tin himself(s). You see, there were four Rinny's on the set: 1 fighting dog, 2 running dogs, and 1 back-up dog! And of course, as the headline star of the show, Rin Tin Tin always travelled first class--everyone else travelled second class! And did you know that young Lee tried out for *Lassie*? He said that at the audition, a big collie ran right up to him, jumped up, and licked him in the face. Lee's surprised reaction was to pushed Lassie away . . . so he didn't get the part!

If you were unlucky, you could get thrown in jail, and if you were lucky, you could get your mug put on a mug. There was a table of items for sale, and lots of things to see that were not for sale. For instance, there were some huge photographs of Crash Corrigan and Silvertown that came from the entrance to Corriganville, and there were a great many 8x10 stills and posters to get misty over. I know I did.

EAGLE POINT POW WOW

On Saturday, May 15th, we dropped in at the Eagle Point Powwow on the shore of Lake Casitas. And WOW it was--what an extravaganza! Put on by the California Indian Education Center of Ventura, this inter-tribal affair brought the dances, the music, the songs, the regalia, and the culture of dozens of tribes to this beautiful spot near Ojai. Among the tribes participating were the Apache, Choctaw, Comanche, Deneh, Hopi, Kiowa, Sioux, Wampanoag, and Wichita.

Upwards of fifty booths of hand-made Indian jewelry, paintings, rugs, blankets, crafts, clothing, weapons, implements, artifacts, books, and delicious food and drink (no alcohol allowed!) surrounded the huge dirt-floor Dance Arena--the focus of all activity. There the powwow began and ended with costumed dancers and singers, and in between were a princess ceremony, honoree recognition, and contests. The characteristic powwow sound was by groups of male singers, called "drums," who beat a drum and sing in unison. While powwows are an Indian event, and usually not directed toward non-Indians or tourists, the Eagle Point Powwow welcomes these visitors, even inviting some to dance while reminding them that the Dance Arena is sacred.

See "Been There" on page 10

Heard at the Meetings

Is **that** Stoney? . . . Yep, and **that** is J.D. . . . Next you're going to tell me **that** is Texas Red . . . Yep . . . Gosh . . . Got me a Red Ryder B.B. gun . . . We're in trouble . . . How was Germany, Durango? . . . Nine hours fast . . . J.D. styled my hat . . . looks super . . . Gonna have J.D. style my hat too . . . Won't do it . . . Will so . . . Will not; J.D. only styles Stetsons . . . Mine's a Stetson . . . Yeah, but it is spelled wrong. There's no \$@#%^&* in Stetson . . . Anyone got some spray paint so I can tone down the shine on Durango's bald head? . . . Have him put on his \$@#%^&* hat . . . Look at that ruffled shirt . . . Buck, the Dude! . . . Got some spurs for Buck that go jingle-jangle-jingle . . . Good, 'cause anyone that would wear a shirt like that should warn people he's coming . . . Good movie, Cowboy! . . . How'd you get the back of your shirt to explode like that? . . . I want to make another one and would like you to be in it, Dusty . . . Have your agent see my agent and let's do lunch!

Dale Evans Receives Angel Award

Congratulations go out to Dale Evans for recently receiving an "Angel Award" for her program on the Trinity Broadcasting Network (TBN). 'Tis just great, but been wondering how in the world they found her program? TBN is always moving her around. 'Tis a hard program to locate and I miss watching it.

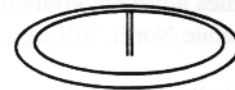

We had Visitors!

Visitors this past month to Trail Rider meetings were Rick Groat, Ron Hayward Sr. and Ron Hayward Jr.



Good to have ya join in on the fun Wranglers!

Rick Groat, along with brother Tag, have brought excitement, action, skills, western stunts, and realism to "The Groat Brothers Wild West Show," as we saw up north in the "Alabams" at the Lone Pine Film Festival.

Trail Riders Hit the Trails

With spring here, several of the Trail Riders are hitting the road. J.D. and Miss Sandy are heading to beautiful Colorado country for a break from Los Angeles. Slick and Miss Marilyn are down in Texas to be there for the birth of their new grand child. Happy trails, podners!

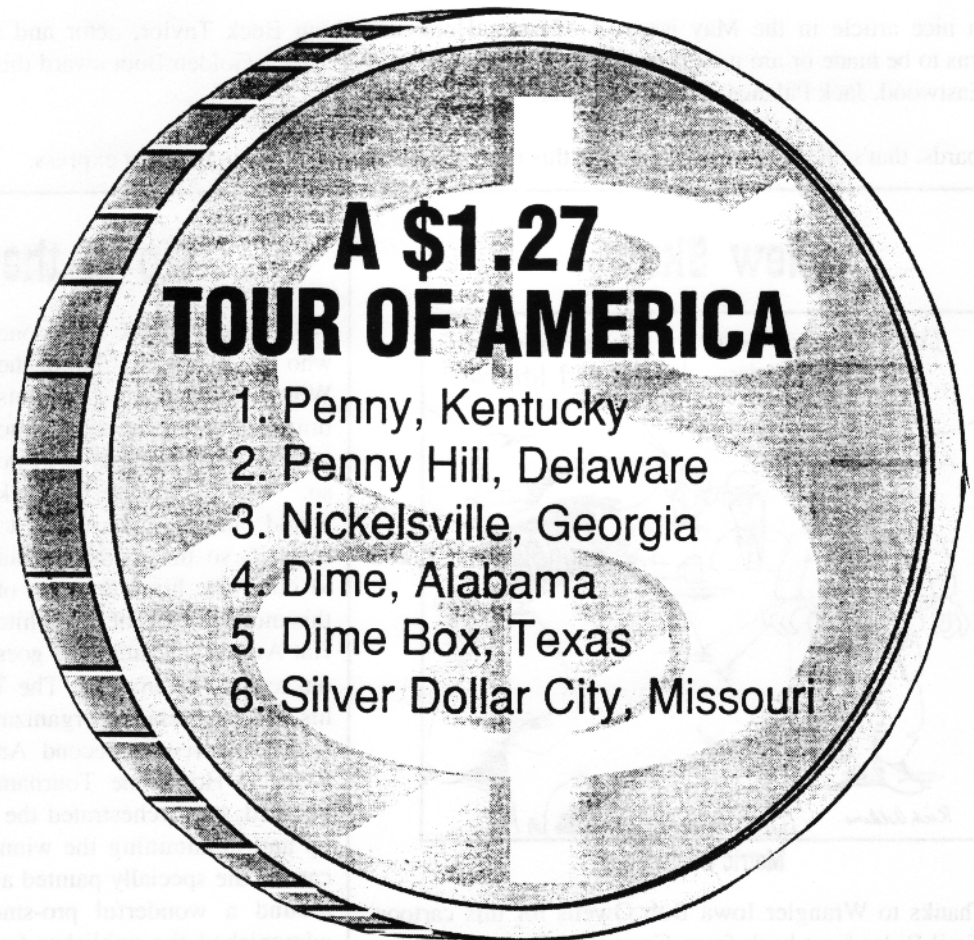

TUMBLEWEED EXPRESS

By Patrick "Stoney" Bousquet

Howdy, pard:

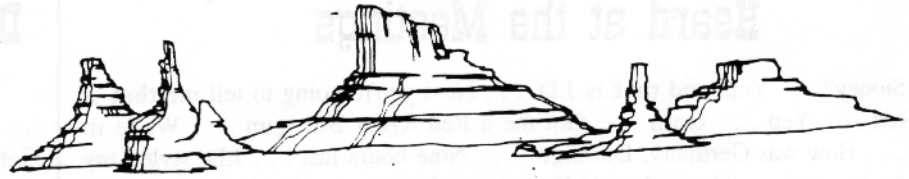

This edition of the express is going to be a little different. I am going to pass on some information that might be of interest.

First off, if any of you enjoy horses and anything connected to the western world, I would encourage you to subscribe to the *Western Horseman* magazine, for \$18.00 a year. Write to *Western Horseman*, Box 542, Mount Morris, Illinois 61054-0542. The *Western Horseman* Consumers Buying Guide will be out in September and it will cover horses and the western market.

Original Will James items are going up for sale; a catalog of items costs \$10.00. Send to Thomas Minckler Gallery, 2907 Second Avenue North, Billings, Montana 59101.

For a free western discount catalog, write State Line Tack, Inc., PO Box 1217, Plaistow, New Hampshire 03865.

A new magazine for buyers and sellers of Western Americana is out at \$25.00 for six issues. Write *Cowboys & Indians*, PO Box 7260, San Carlos, California 94070.

For you Montie Montana fans, his autobiography is available. Ask for "Montie Montana, Not Without My Horse. Send \$19.95 plus \$2.95 S&H to Double M Co., Box 6102, Agua Dulce, California 91350.

Want to make your own period shirts? Get a pattern catalog for \$1.00 from Buckaroo Bobbins, 2304 Rembrandt Drive, Dept. WH, Las Vegas, Nevada 98128.

Read a nice article in the May issue of *Western Horseman* about Buck Taylor, actor and artist, tells about the upcoming Westerns to be made or are now being filmed. Buck will be receiving a Golden Boot award this year along with other honorees Clint Eastwood, Jack Palance, and Jane Fonda.

Well, pard, that's all the smoke signals for this time. Hope to have more in the next express.

Stoney

New Skew



Metric cowboys.

Thanks to Wrangler Iowa Bob Owens for this cartoon. Had Trail Rider "just back from Germany" Durango explain it to me. Metric numbers just aren't the same are they?

Tip of the White Hat

Well, usually Buck is the one who hands out the "Tip of the White Hat" awards, but this time it is the membership who took it unto themselves to do so. Why? Because of Buck would never give one to himself, so the members had to do it for him! So, one of this month's "Tip of the White Hat Award" nominations goes

out to the Foreman of "The Trail Riders of the West" for all his special brand of organization in creating and bringing to reality the recent Second Annual Lee "Duke" Barker's Red River D Horseshoe Tournament. Buck is the one not only planned, but orchestrated the entire tournament from making up and maintaining the winners chart to creating and taking care of the specially painted awards! Buck drew up and passed around a wonderful pro-smoking cartoon and never once admonished the publisher for misspelling "horseshoe" in the event's flyer title. Congratulations to Buck from the members!

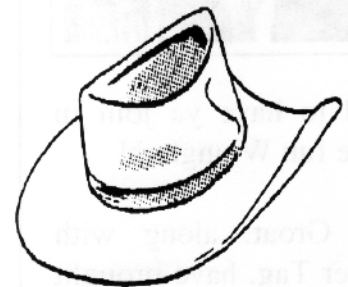

The Horseshoe Tournament . . . a Retrospective

A better day could not have been possible to have the "Second Annual Lee 'Duke' Barker's Red River D Horseshoe Tournament." Sunday, May 2nd, was just a wonderful day full of bright and warm sun made comfortable with a gentle breeze. Fourteen Trail Riders and Riderettes competed, joked, got caught losing to Durango a good time! Just ask Texas Red's drive to Trail Riders for a second year. So, Durango has reigning (or is that "reining") winner of Lee's 1993 Charles King Shoe Award, Kiowa Slim the Too Much Grass Award, whereupon he he and all the other Trail Riders and Riderettes Ranch main house. Dinner consisted of chili thanks to Miss Joyce, veggy plate and dip thanks Miss Marilyn and Slick, lots of good-tastin' camp and a great cake for desert thanks to Miss Nancy. cowpoke riding a broomstick horse in a little any cookin'? Was thought a wise decision, but and lemonade. Buck didn't. The whole day was good and all are looking forward to the next Trail Rider tournament which will be held Sunday, June 13th--the "Fourth Annual Great Red Ryder Daisy B.B. Shoot-out."



Tip of the White Hat

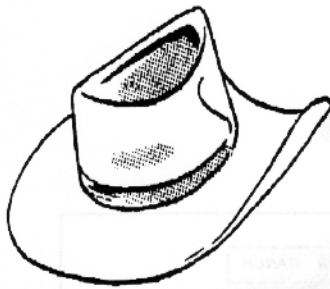

A "Tip of the White Hat" goes out to two deserving Trail Riders: Roper, for furnishing the horseshoes off of his horse Pistol that were used as awards for Lee's Tourney, and Durango for mounting them on beautiful wood plaques. Well done, Trail Riders!

Hoppy's Bike CONTINUED FROM PAGE 1

\$6000.00 in hard cash! This bike is the same popular bicycle of the 1950s that was introduced as "the original cowboy bicycle" and cherished by young fans of "Hoppy" and his faithful horse Topper. Made by the D.P. Harris Hardware Manufacturing Company of New York, only 12 are currently available and each sturdy bike has been carefully restored to a like-new condition. It displays all the unique features of the original including the Hopalong medallion and Hopalong Cassidy signature on the oversized "gas tank," a white diamond and circle design chain guard and paper carrier, and silver and gold handlebar tassels. The 3-1/4-inch-wide front and rear fenders and spring suspension leather seat are also original parts. Its curved headlight and pushbutton horn (set in the gas tank) each use two D-cell batteries (included). Each bike also comes with 2-1/2-inch-thick whitewall balloon tires. Professional assembly is recommended, and the bike is available in 26-inch men's frame only. Coincidentally, that is exactly the size that Hoppy aficionado Jack "Buck" Harding rides, so if anyone is looking for a just a little something for Buck's birthday, the catalog number is 16787M . . .

Your 1993 Trail Rider Officers

FOREMAN

Jack "Buck" Harding
1053 Erringer Road
Simi Valley, California 93065
(805) 522-8472

LEAD WRANGLER

Patrick "Stoney" Bousquet
1936 Arcane Street
Simi Valley, California 93065
(805) 527-9653 - for Trail Riders only please

BANKER

Don "Dusty" Maiers
1218 Alexander Street
Simi Valley, California 93065

CLERK

Dick "Colorado" Oakes
2992 Kadota Street
Simi Valley, California 93063
(803) 583-2241

RAMROD

Tim "Durango" McIlvain
10957 Sonora Avenue
Rancho Cucamonga, California 91730
(714) 941-7340 - weekends



Fourth Annual Great RED RYDER™ Daisy® B.B. Shoot-out

SUNDAY, JUNE 13, 1993
1 p.m. to 3 p.m.

Special Patio Dinner
Exciting Awards Ceremonies

Tournament is open to all current-dues-paid Trail Riders and their Riderettes

The rules are simple: Only official Daisy Red Ryder B.B. Rifles can be used in the Tournament. Whoever hits the target with the most points each elimination round moves on to the next round. This is a single-elimination tournament. Awards presented to the top four places.

Please contact Jack "Buck" Harding at (805) 522-8472 if you have any questions about this tournament.



You've all been talkin' about it and now it's here! Have a great time Trail Riders and Riderettes. And defend your 1992 title well, Colorado! You can do it, buckaroo!

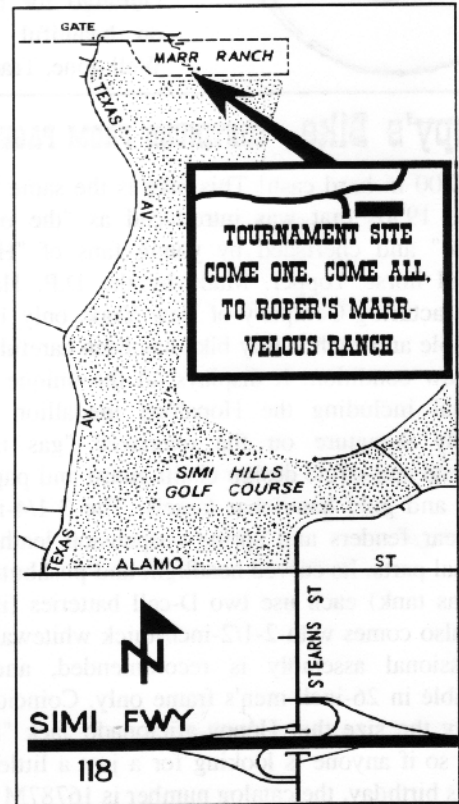

Trail Drive Scheduled to

A Trail Drive is forming up for Saturday, June 19th, for members of the Trail Riders and Riderettes to attend The Hollywood Collector's Show at Beverly Garland's Howard Johnson's Hotel in North Hollywood. Trail Drive will head This will be the club's fourteenth Trail Drive to always a fun day. Contact Buck to assure your spot



Hollywood Collector's Show

19th, for members of the Trail Riders and Show at Beverly Garland's Howard Johnson's 'em in and move 'em out from 9:30 a.m. to 4 p.m. this event and we've never had a nasty time-- on the Trail Drive. You'll be glad you did.

Trail Riders' June Schedule.



- June 2 Special Birthday Meeting at Roper's MARR-velous Ranch
- June 9 Regular meeting at Roper's MARR-velous Ranch
- June 13 The Great Red Ryder Daisy B.B. Shoot-out at Roper's MARR-velous Ranch
- June 16 Select tournament at regular meeting at Roper's MARR-velous Ranch
- June 16 Recycling collection and dues are payable
- June 23 Regular meeting at Roper's MARR-velous Ranch
- June 30 Special Dinner and "A" Feature Western. Meeting open to all Riders and Riderettes at Roper's MARR-velous Ranch.

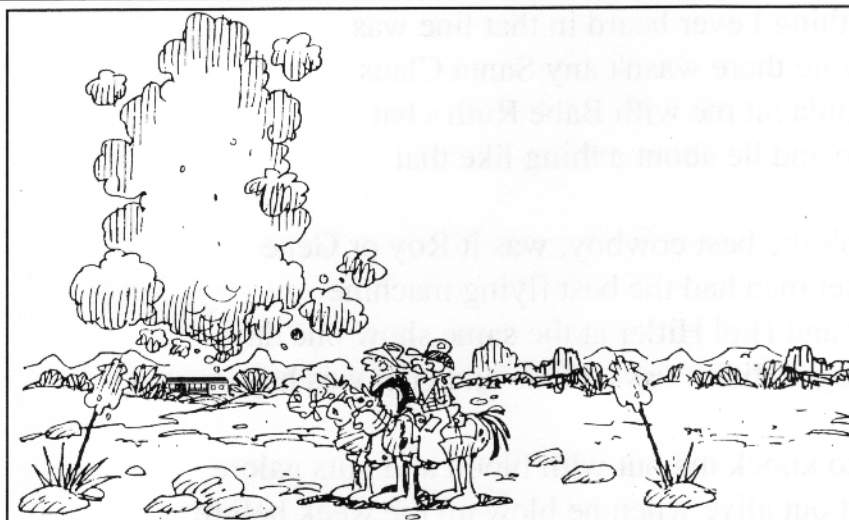

Write your favorite caption here:

" _____ "

Budd Buster Says:

"You know, I just don't understand today's drive to make a lot of money so you can own all of the 1990s things. There's more to life than owning the biggest and the most expensive of everything. For example . . . paying the bills!"

SAY, BUDD . . .

Did you know that Black Bart robbed 29 sage coaches from 1875 to 1883 and always worked with an unloaded gun? Guess he was after owning all those 1880s things and had trouble paying the bills, huh?

Movies Watched in April

- April 7 Movie: *West of El Dorado*, starring Johnny Mack Brown
- April 14 Trailers: *Movie Trailers*, starring Rick and Tag Groat
- Movie: *Sing, Cowboy, Sing*, starring Tex Ritter
- April 21 Movie: *Hit the Saddle* starring The Three Mesquiteers (Livingston, Corrigan, Terhune)
- April 28 Short: *Bloodmoney*, starring Tom "Cowboy" Ratican
- Movie: *Border Phantom*, starring Battlin' Bob Steele



SATURDAY MATINEE

You read about new Trail Rider Will "Kiowa Slim" Lacey on the front of this issue of THE TRAIL RIDER and how he likes to write Americana Poetry. Well, here is a sample of his writing. 'Tis neat. I have a newspaper clipping of this one I got from our local paper a while back. Thought then, "Gee, this guy should be in the Trail Riders" . . . and now he is, I am happy to say. 'Tis a small and wonderful world, huh? Yep!

I was about six years old the first time I went
I think then Harry Truman was the President
It was a whole lot different than is today
I'm talking about the Saturday Movie Matinee

We'd get there early probably an hour or more
And eat popcorn and talk before they opened the door
I heard a lot of good jokes there shootin' the breeze
And I think that's where I learned about the birds and bees

But the worst thing I ever heard in that line was
Somebody swore there wasn't any Santa Claus
Now you coulda hit me with Babe Ruth's bat
But don't go and lie about a thing like that

And we'd argue who's the best cowboy, was it Roy or Gene
And which rocket man had the best flying machine
I'd heard Hi-Yo-Silver and Hiel Hitler at the same show one day
And for a while I thought Hitler was a horse and Hiel was hay

And those serials used to knock me out with blood and guts galore
And how did that guy get out alive when he blew up the week before
The Little Rascals and the Three Stooges were my favorites though
But you could throw in little Bugs Bunny to make it a perfect show

Lots of times we'd sit through twice and learn every thing they said
So the next week at school it was you who'd tell everyone who knocked 'em dead
Sometimes in that second show when I'd learned the first show text
I'd really make people mad when I'd tell 'em what was next

Yes, the Saturday afternoon movie matinee
When I was a kid was a neat time to play
They chased them outlaws from border to border
And the whole darn thing only cost a quarter.

By Will Lacey

July 7, 1992

Comin' Up!

Ya probably spotted the notice in June's Trail Riders activities schedule. Now, here is what that "Select Tournament" listing is all about. It comes from the January Board of Directors meeting where the future focus of the Trail Riders would take a social club direction and one of stressing Saturday matinee Westerns information. That one was handled by adding a cover page to THE TRAIL RIDER and salute a particular birthday falls during the and show a film featuring meeting of that month. Riders evolved from that was added to that meeting. up the third-week dues-eliminating the serial and tournament. The first dart tournament consist-tourney will be a single- and whoever scores the moves onto the next semi-final rounds, and round. the tournament winner each month will receive a prize. Darts is only one venue in the tournament schedule. A dart gun shooting tournament (the ones with the rubber suckers on the end) is being considered as well as a marble tourney. The schedule is wide open for ideas. All will be short and fun. Maybe a gun twirling contest? Who knows, but in June, we'll be competing in darts.

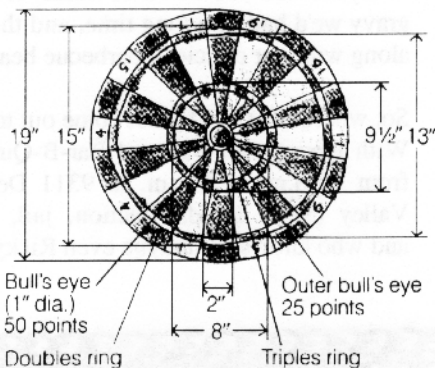

Western actor whose month of that newsletter him at the first week The birthday party for Trail idea and a birthday cake Next they decided to lighten paying meeting by adding a fun short third-week tourney will be a ing of two throws only. The elimination tourna-ment most points in their pairing elimination rounds, then finally to the champion-ship

A Side Note

From that same Board meeting in January, it was decided to add another tournament to the club's already three-tournament schedule (horseshoe, B.B. gun, and roping). Coming in July will be the First Annual Fast Draw Face-off Tournament! This should really be a fun day, huh? All the details of the tourney will be in the next issue of THE TRAIL RIDER.

Captions

On page 7, you had the chance to create a cartoon caption. How'd ya do? Here are a couple of possibilities if you couldn't come up with one:

"Looks like Roper's makin' toast, again!"

"I bet Roper rubbed that funny old lamp he found buried in the corral!"

"I think its ol' Roper makin' a smoke signal to Miss Nancy, tellin' her to bring home some more popcorn!"

"Maybe Roper put too many logs in the fireplace for a Trail Rider meeting!"

"I told Roper to stop singin' that old Indian rain-makin' chant!"

"J.D. must be firin' up the kettle again to block and form ol' Roper's hat!"

"Guess there's a Trail Rider meetin' goin' on at the old MARR ranch, and some cowpoke musta opened the door to the patio."

Matinee Q&A

Selected by Dick "Colorado" Oakes

Test your matinee savvy with this quiz. We'll start with a really easy one:

1. Who played the part of "Singin' Sandy," the singing cowboy, in the 1933 musical Western *Riders of Destiny*?
2. What famous leading man began his film career with a walk-on part in the Hopalong Cassidy film *Hoppy Serves a Writ*, released in 1934?
3. In what Hollywood Western did John Wayne appear in his first leading role and who was its director?
4. What 1935 Western made Gene Autry a national star as America's "singing cowboy"?
5. Who was the most popular woman in Westerns?
6. What was Roy Rogers's first full-time job in Hollywood?
7. What early "B" Western cowboy actor played a bit part in the 1963 John Wayne Western *McLintock*?
8. How long did it take to shoot the Roy Rogers and Gene Autry movies of the 1930s?
9. What was wrong with Ken Maynard's star horse, Tarzan?
10. What did Ken Maynard, Buck Jones, Bob Steele, Tim Holt, Johnny Mack Brown, Donald Barry, William Elliott, Lash LaRue, and William Boyd have in common?

ANSWERS: 1. John Wayne; 2. Robert Taylor; 3. The Big Trail directed by Raoul Walsh; 4. Tumbling Tumbleweeds; 5. Based on her longevity as a Western genre star, the likeliest candidate for this achievement is probably Dale Evans; 6. In 1929 Rogers came to California from Ohio and landed a job picking fruit in an orchard near Los Angeles; 7. Bob Steele played an aging railroad employee in *McLintock*; 8. About a week; 9. His eyesight was so poor, he often bumped into objects; 10. All were stars of "B" Westerns during the 1930s.

Been There CONTINUED FROM PAGE 2

As might be expected, the celebrities at the powwow mostly were Indians, although their names are probably unknown outside of Indian culture. But the name of one celebrity there you would recognize: Ricky "The Spider" Silva, giving adoring folks a display of his fancy gun twirling.

CHUCK WAGON TRAILERS

On Sunday, May 16th, we took in a couple of hours of the fund raising event for the Chuck Wagon Trailers at the Simi Valley Moose Lodge. Folks on hand during that time were Buck and Miss Joyce and Wrangler Dave Pitts. Entertainment

was provided by The Overland Express and the MC was Dennis Morgan Strange. Many celebrities were there, including Iron Eyes Cody, Montie and Marilee Montana, Lee Aakers, Tom Corrigan, Foggy Mountain, Bill Nolt, Ermal Williamson, Steve Gillum and his Corriganville Players, and you guessed it . . . Ricky "The Spider" Silva twirling his guns! Everyone chowed down to some of the best roast beef and gravy we'd had in a long time, and there was plenty of it to go along with our delicious barbecue beans and peaches.

So, what's next? Why not come out to the 12th Annual Ahead With Horses Fun Day and Bar-B-Que on Sunday, June 13th, from 10 a.m. to 6 p.m. at 9311 Del Arroyo Drive, in Sun Valley (\$10). Bands, auction, jail, Clydesdales, celebrities, and who knows . . . maybe even Ricky "The Spider" Silva!

Rounding-Up with Buck

I sure have enjoyed April and May. All the long business meetings and Board meetings of this past winter are really showing. Every aspect of the Trail Riders is more relaxed since the strong direction of being more of a social club. Like it. Like it a lot. Sure glad to have Grizz and Kiowa Slim with us. Had a lot of fun at Lee's Annual Horseshoe whingding and looking forward to Red Ryder day coming up. Wishing everybody a good June and I'll be writing with ya again next month Trail Riders.

Buck
—



THE TRAIL RIDER



THE TRAIL RIDER is published monthly for the members of "The Trail Riders of the West," and is distributed the third Wednesday of each month. The deadline for submitting articles is 9:00 PM on the last Saturday of the month for the following month's issue. Please submit articles to Buck at any Trail Riders meeting, or mail them to Jack R. Harding, 1053 Erringer Road, Simi Valley, California 93065. For Trail Rider information, telephone Buck at (805) 522-8472.

Editor-in-Chief and Writer.....Jack R. "Buck" Harding
Publisher.....Dick "Colorado" Oakes
Contributors..... Patrick "Stoney" Bousquet, Will "Kiowa Slim" Lacey, Dick "Colorado" Oakes